

# Comprehensive Sign Package



March 5, 2007  
Revised  
April 4, 2007  
Revised  
June 15, 2007  
Revised  
July 26, 2007  
Revised  
August 20, 2007  
Revised  
September 4, 2007  
Revised  
September 21, 2007



Prepared for

**Pender LLC**

**By: Atlantic Realty, Inc.**

8150 Leesburg Pike, Suite 1100

Vienna, VA 22182

(703) 760-9500

Prepared by

**Rounds VanDuzer Architects**

467-A North Washington Street

Falls Church, VA 22046

(703) 533-3577

Table of Contents

Introduction	3
• Map	4
• Logo	6
• General Provisions	7
• Sign Matrix	8
Sign Types	
1. Monument Signs	11
• Pender Village Center (Primary)	13
• Pender Village Center (Secondary)	14
• Pender Executive Center	15
• Directional Signs (Primary)	16
• Directional Signs (Secondary)	17
2. Tenant Signs	18
• Anchor Tenant	21
• B-1 Building Retail Signs	24
• 1 <sup>st</sup> Floor Retail	25
• 2 <sup>nd</sup> Floor Office	26
• Existing Office Building	27
• Office Building	28
• Pad Building	29
• Retail Blade Signs	34
3. Miscellaneous Signs	36
• Garage Entrance Signs	38
• Protected Natural Area Sign	40
• Light Pole Mounted Banners	41
• Historical Marker	42
• Flags	43
▪ Informational Signs	44
○ Stop/ Yield	
○ Handicapped	
○ No Parking	
○ Play Area	
○ Loading / Receiving	

## Introduction

### Pender Village Center (PVC) and Executive Center (PEC)

The purpose of the Comprehensive Sign Package is to establish a cohesive, comprehensive, distinctive, and functional system to direct and communicate with those who work or visit the shops and offices. The signs provide a consistent source of information while reflecting the high standards of design and visual quality, which are a cornerstone of the development.

Well-designed signage is an integral part of any successful project. The purpose of a sign system is to orient, inform, direct, and regulate pedestrian and vehicular traffic. A properly conceived signage system will also enhance the visual quality of the development and enhance the safety of the traveling public.

Signage, as visual communication, is most effective when organized in a comprehensive, cohesive system. The sign system is designed to achieve a consistent display of information throughout the development. The elements of this system reflect and emphasize the architectural style and landscape features of PVC and PEC, and allow for the flexibility this community will need over the next 10 to 15 years as it continues to grow.

The following pages provide illustrations, details, locations, and types of messages, for the various signs on the site. These guidelines assure consistent display of information, and create a comprehensive sign program, which will establish an overall identity, convey information, direct traffic and facilitate access to PVC services and amenities.

Since all new Retail and Retail/Office buildings are proffered and designed with four-sided architecture, maximum signage area is presumed to be (based on Fairfax County standards) as if all sides were street-facing and allowed signage. That the total amount of signage so computed can be allotted where it best directs, advertises and informs is also assumed.



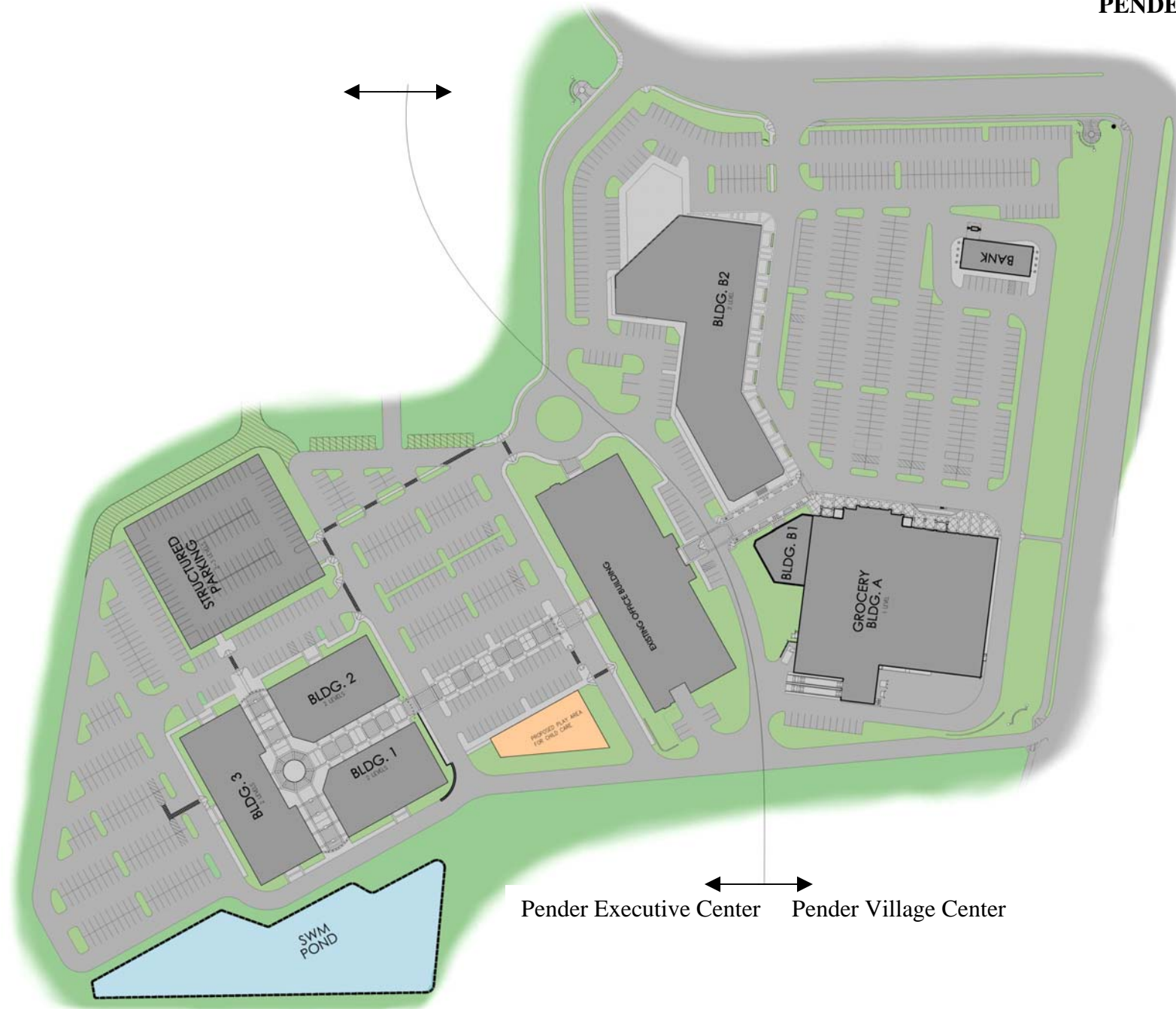

Pender Executive Center    Pender Village Center

## Pender Village Center and Executive Center Logos









To create a sense of unity in the Pender Village Center and the Pender Executive Center, a consistent logo type has been created. There are several iterations of the logo used to create a cohesive look while still maintaining flexibility to accommodate varying formats. It will be used on entrance signs and other monument signs to create a sense of entering. It will also be used throughout the Centers as branding to create a sense of community and identity in the Pender Community. The logo presented here is the preliminary logo. Shape, text, colors and fonts may be modified to reflect future marketing conditions. If the logo is modified, all logos will be changed to maintain the unity of the space. All logos used will be consistent in colors and fonts.







### Pender Executive Center





## General Provisions

1. The signs shall be built in substantial conformation with the designs illustrated in this sign package, final design changes based on engineering of signs may occur, but will not substantially alter the design.
2. Lighting of signs shall not be blinding, fluctuating or moving.
3. All signs shall comply with applicable requirements of the building codes. No sign shall obstruct required site distances or sight triangles.
4. Notwithstanding the number of signs shown in this package, applicant will not be obligated to construct every sign shown.
5. Sign sizes depicted provide maximum square footage. Sign size may be reduced providing sign is substantially similar to sign depicted
6. This Sign Package does not regulate signage inside of buildings.
7. Tenants are not fixed and any names are shown for illustrative purposes, exact locations and number of tenants are subject to change based on tenant mix.
8. Logos with less than 1 s.f. of area and containing no text may be used throughout the site to help reinforce identity of this planned development without being counted as a sign.
9. Low-lying shrubs, boulder rock massing and/or flowering plants will be provided around the base of permanent monument signs.
10. Building mounted signs provide key identifiers for tenants, and vary in size according to the size of the tenant. Each tenant shall be permitted to install building mounted signage in accordance with the applicable CSP.
11. Building frontage, which is one determinant of the amount of signage available to an individual tenant, is defined to include all building facades for a tenant.
12. All signs shall be fabricated and installed in accordance with the following requirements:
  - (a) The sign lettering of any part or parts thereof shall be located within the physical limits of the sign area.
  - (b) All signs shall be fabricated and installed in compliance with all applicable codes. All signs shall have appropriate UL stickers attached to the top of each letter.
  - (c) Signage shall not come within 1 foot 6 inch spacing of the end of individual demising frontage, so as not to encroach on adjacent tenant signs.
13. Painting or printing signs on the exterior surface of any building shall be prohibited except small scale signs relative to store name, address and stating store hours which are neatly lettered on the glass of the storefront, subject to landlord's approval. In addition, any non-customer door for receiving merchandise may have signage in 2-inch block letters, which identifies the tenant.

RETAIL & OFFICE SIGNAGE FOR PENDER VILLAGE CENTER & PENDER EXECUTIVE CENTER								
Type of Sign	Sec.12 - Zoning Ordinance	PROPOSED						
		Symbol for Sign	Sign Use	Description of Sign	Max SF of Sign	Letter/Logo Size	Mounting Height Range	Letter / Logo Face/Edge Color
Monument Signs	Sec. 12-205 (3) <b>80 SF</b> maximum 1 sign		Pender Village Center Sign (Primary)	Backlit Panel signs mounted on EIFS Background, with Stone Base, ground mounted lights	<b>208 SF</b>	Panel height is 1'-10" per tenant, 5 panels	Overall sign is 16'-0" in height, Panels are 1'-10" in height	White letters on medium dark panel
			Pender Village Center Sign (Secondary)	Backlit Panel signs mounted on EIFS Background, with Stone Base, ground mounted lights	<b>118 SF</b>	Panel height is 1'-5" per tenant, 5 panels	Overall sign is 12'-0" in height, Panels are 1'-5" in height	White letters on medium dark panel
			Pender Executive Center Sign	Pin Mounted letters on brick or hardiboard background, with stone accents, ground mounted lights	<b>42 SF</b>	1'-3" letter height	Overall sign is 3'-0" in height	Gold or Green pin mounted letters, Black edge
Directional Signage	Sec. 12-203 (13 C) <b>15 SF</b> maximum each		Pender Directional Signs (Primary)	Routed letters on Hardiboard mounted on Stone Base, ground mounted lights	<b>15 SF</b>	varies	Overall sign is 4'-0" in height	White letters on green panel
			Pender Directional Signs (Secondary)	Routed letters metal mounted on Stone Base, no illumination	<b>approx. 4 SF</b>	varies	Overall sign is 2'-6" in height	White letters on dark panel
Blade Signs	not addressed in ordinance		Retail Blade Signs Canopy Mounted	Wooden or Metal Blade signs with Tenant Name & PVC logo (optional), no Tenant logos allowed; single color	<b>5 SF</b> maximum; 1 Sign/Tenant	4" letter height	Mounted under canopy	Gold PMS 7406, Green PMS 5545 edge/material
			Retail Blade Signs Cantilever Mounted	Wooden or Metal Blade signs with Tenant Name & PVC logo (optional), no Tenant logos allowed; single color	<b>5 SF</b> maximum; 1 Sign/Tenant	4" letter height	Mounted under canopy	Gold PMS 7406, Green PMS 5545 edge/material
Building Mounted Tenant Signs	Sec. 12-203 (8) <b>295 SF</b> maximum		Anchor Tenant Signs (Building A)	Channel Letters on Raceway, lit box tagline, individual logos; raceway to match bldg exterior	<b>422 SF</b> distributed across multiple signs	varies, 3'-6" letter height; logo height 4'-0"	Below roof line	Varies; Black edge







RETAIL & OFFICE SIGNAGE FOR PENDER VILLAGE CENTER & PENDER EXECUTIVE CENTER								
Type of Sign	Sec.12 - Zoning Ordinance	PROPOSED						
		Symbol for Sign	Sign Use	Description of Sign	Max SF of Sign	Letter/Logo Size	Mounting Height Range	Letter / Logo Face/Edge Color
Building Mounted Tenant Signs	Sec. 12-203 (9) <b>200 SF</b> maximum per tenant, included in totals below		<b>Building B1 &amp; B2 Major Retail Tenant Signs</b>	Individual internally illuminated channel letters with Plexiglas face lens mounted on building façade on raceway to match bldg	<b>75 SF</b> maximum, per tenant included in totals below	3'-6" letter height; logo height 4'-0"	Below roof line	Varies; Black edge
	Sec. 12-203 (9) <b>125 SF</b> maximum for bldg		<b>Building B1 Retail Tenant Signs</b>	Individual internally illuminated channel letters with Plexiglas face lens mounted on building façade on raceway	<b>180 SF total for building,</b> 60 SF maximum per tenant	1'-6" letter height, logo height 3'-0"	Below roof line	Varies; Black edge
	Sec. 12-203 (9) <b>1020 SF</b> maximum for bldg		<b>1st Flr Retail Tenant Signs Building B2</b>	Individual internally illuminated channel letters with Plexiglas face lens mounted on building façade on raceway	<b>1500 SF total for building,</b> 60 SF maximum per tenant	1'-6" letter height, logo height 3'-0"	Below roof line	Varies; Black edge
Building Mounted Tenant Signs	Sec. 12-203 (8) <b>731 SF</b> maximum for bldg		<b>2nd Floor Office Tenant Signs Building B2</b>	Individual internally illuminated channel letters with plexiglass face lens mounted on building façade on raceway to match bldg; rear tenants of 4000 SF+ will be allowed sign area on frontage	<b>900 SF total for building,</b> 60 SF maximum per tenant	1'-6" letter height, logo height 3'-0"	Below roof line	Varies; Black edge
	Sec. 12-203 (9) <b>200 SF</b> maximum per tenant included in total above		<b>Major Office Tenant Signs (2nd Flr) Building B2</b>	Individual internally illuminated channel letters with plexiglass face lens mounted on building façade on raceway to match bldg	<b>75 SF</b> maximum per tenant , included in total above	3'-6" letter height; logo height 4'-0"	Below roof line	Varies; Black edge

RETAIL & OFFICE SIGNAGE FOR PENDER VILLAGE CENTER & PENDER EXECUTIVE CENTER								
Type of Sign	Sec.12 - Zoning Ordinance	PROPOSED						
		Symbol for Sign	Sign Use	Description of Sign	Max SF of Sign	Letter/Logo Size	Mounting Height Range	Letter / Logo Face/Edge Color
Building Mounted Tenant Signs	Sec. 12-203 (8) <b>135 SF</b> maximum		<b>Pad Building (Bank)</b>	Individual internally illuminated channel letters with plexiglass face lens mounted on building façade on raceway to match bldg	<b>approx. 150 SF for Building</b>	1'-6" letter height	Below roof line	Varies; Black edge
Building Mounted Tenant Signs	Sec. 12-203 (8) <b>365 SF</b> maximum		<b>3901 Fair Ridge Drive (Existing Office Bldg)</b>	Individual internally illuminated channel letters with plexiglass face lens mounted on building façade on raceway to match bldg	<b>360 SF total, for building</b> 4 tenant signs maximum at 90 SF each	1'-8" letter height, logo height 2'-6"	Below roof line	Varies; Black edge
Building Mounted Tenant Signs	Sec. 12-203 (8) <b>670 SF max for 3 bldgs</b> Bldg 1 = 270 SF Bldg 2 = 200 SF Bldg 3 = 200 SF		<b>Office Building (Bldgs 1, 2, 3)</b>	Individual pin mounted letters, solid, uniform font & color, no illumination	<b>30 SF maximum per tenant;</b> tenant layout is not currently available	1'-6" letter height, logo height 2'-6"	Below roof line	Black; Black edge
			<b>Major Tenant Office Building (Bldgs 1, 2, 3)</b>	Individual pin mounted letters, solid, uniform font & color, no illumination	<b>120 SF total,</b> 2 major tenant signs per building, 60 SF maximum per tenant	3'-0" letter height, logo height 3'-6"	Below roof line	Black; Black edge
Misc. Signs	no maximum SF noted in Ordinance		Seasonal Banners on Light Poles	Screen printed fabric of metal panels mounted on light poles	<b>18 SF per banner</b>	N/A	17'-6" to 25'-0"	Varies
	not addressed in ordinance		Informational Signs	Stop, Yield, etc.	In conformance with VDOT/state & federal standards	N/A	In conformance with VDOT/state & federal standards	In conformance with VDOT/state & federal standards

# Monument Signs

A hierarchy of monument signs for Pender has been developed to correspond to the hierarchy of entrance points and directional information. Substantial ground mounted signs denote key entrances while secondary entrances are marked with signs that are smaller but of a consistent design type.

Directional signs to assist in general flow through the site are designed to be visually legible at a larger range, while signs intended to direct smaller traffic patterns such as parking areas or movement through the drive-through bank teller, are smaller for more concise instruction. The plan shows probable locations for these signs. Locations are subject to change due to final design and engineering requirements. Because of the fluctuations in design and market conditions, flexibility is needed to relocate directional signs for future leasing conditions; directional sign locations may be modified by the Fairfax County Department of Planning and Zoning so long as they are in substantial conformance with the applicable CSP.

-  Pender Village Center Sign (Primary)
-  Pender Village Center Sign (Secondary)
-  Pender Executive Center Sign
-  Pender Directional Sign (Primary)
-  Pender Directional Sign (Secondary)

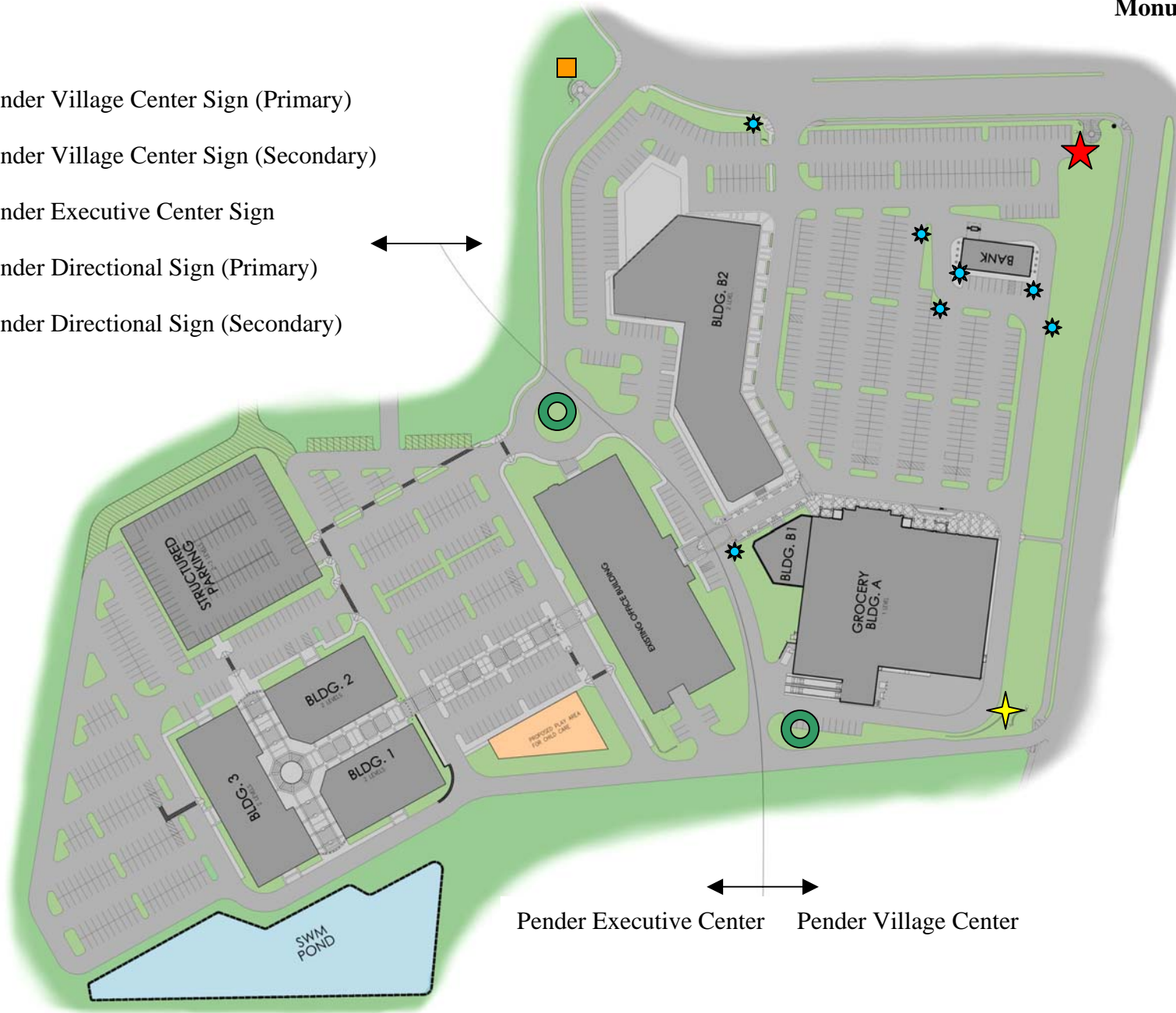

★ **Pender Village Center Sign (Primary):**

This monument sign marks the entrance at the corner of Lee Jackson Memorial Hwy and Fair Ridge Drive. It displays the names of major tenants in order to provide visibility to vehicular traffic. The entrance feature may incorporate the name and logo of the center. It will be illuminated internally.

**DESCRIPTION:**

Panel signs mounted on EIFS background with stone base  
208 S.F. max sign area

**GRAPHICS / LETTERING**

- White letters (reveal) on Medium dark panel cutout
- Logo mounted to EIFS, backlit
- Corporate logos allowed
- 1' – 10" Sign Bands
- Internal Illumination

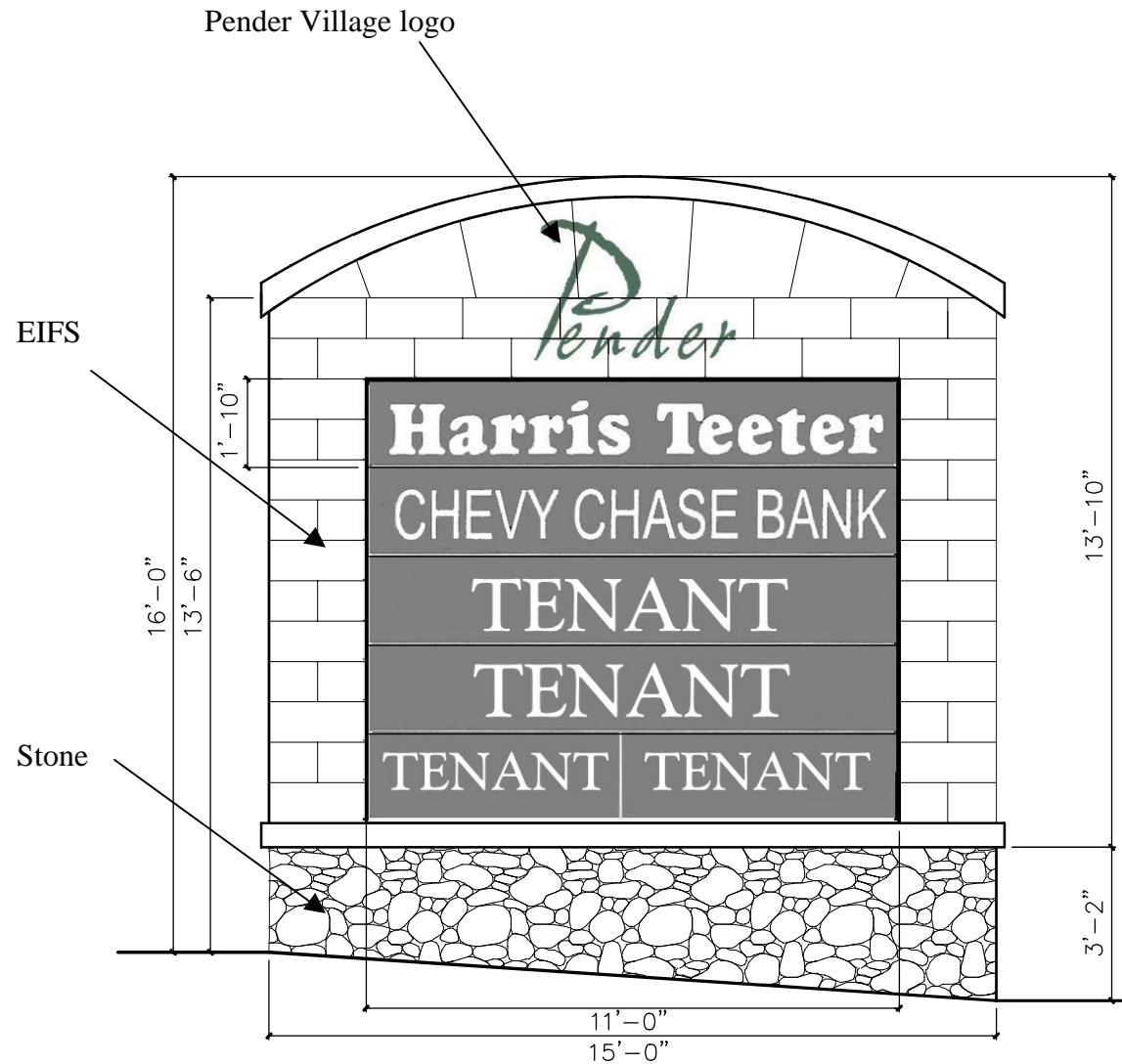

■ **Pender Village Center Sign (Secondary):**

This monument sign marks the entrance on Fair Ridge Drive. It displays tenant names for vehicular traffic approaching the center from the North. The entrance feature may incorporate the name and logo of the center. It will be illuminated internally.

**DESCRIPTION:**

Panel signs mounted on EIFS background with stone base  
118 S.F. max sign area

**GRAPHICS / LETTERING**

White letters (reveal) on Medium dark panel cutout  
Logo mounted to EIFS, backlit  
Corporate logos allowed  
1' – 5" Sign Bands  
Internal Illumination

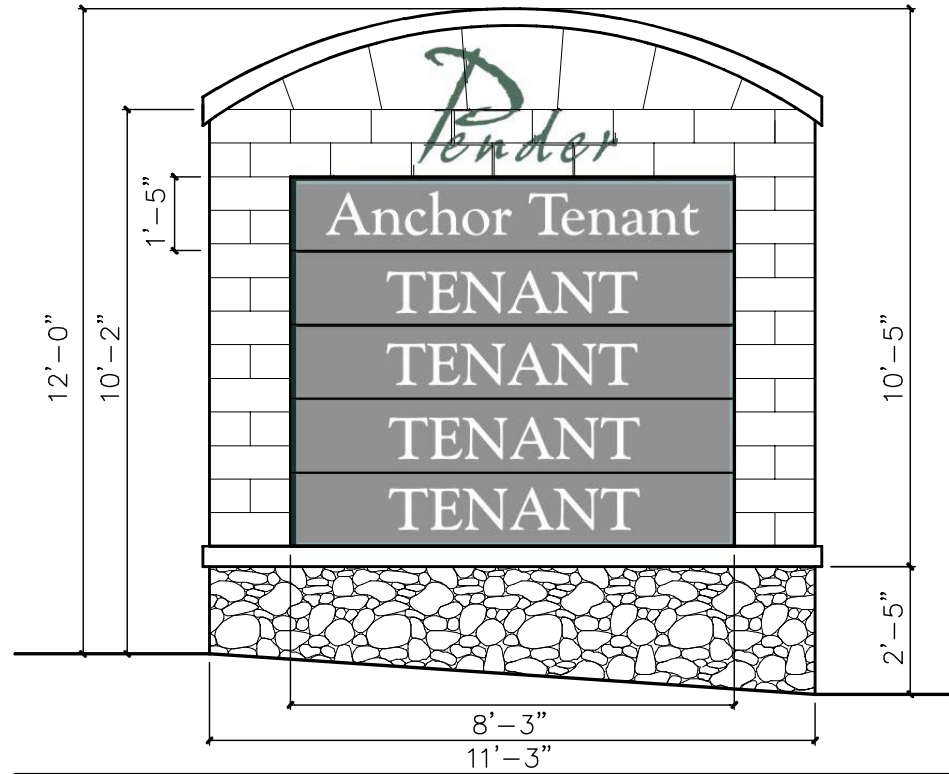

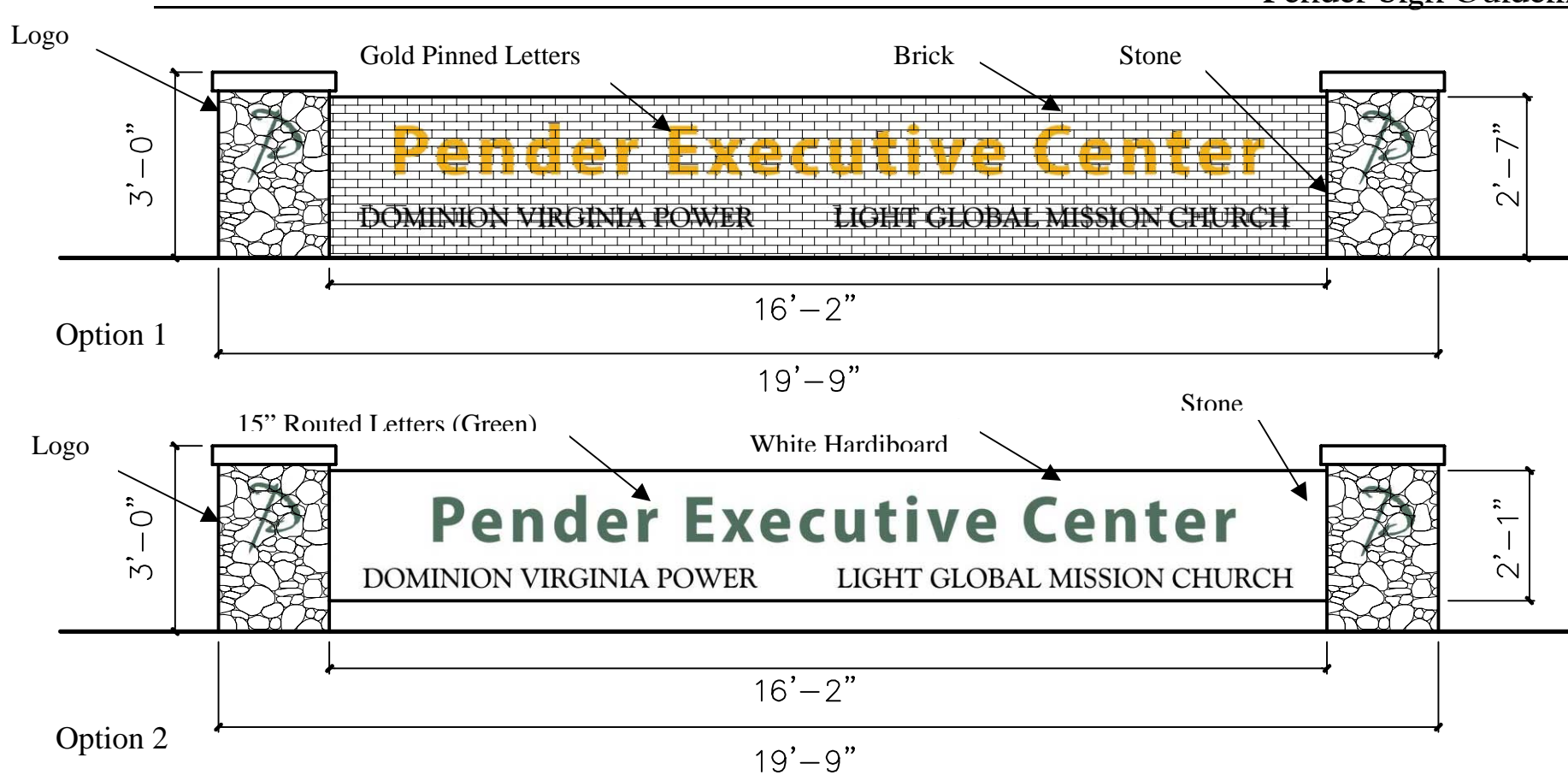

✦ **Pender Executive Center Sign:**

The Executive Center sign marks the entrance to the office portion of the center. It displays the name of the center and the names of major tenants. The sign will have backlighting (halo lighting) behind the pin mounted letters

**DESCRIPTION:**

Option 1 Gold pin mounted letters on brick background

Option 2 Letters routed in Hardiboard background

42 S.F. max sign area

**GRAPHICS / LETTERING**

Font: Grimshaw Hand, Myriad Pro

Letter Height: 1'3" max

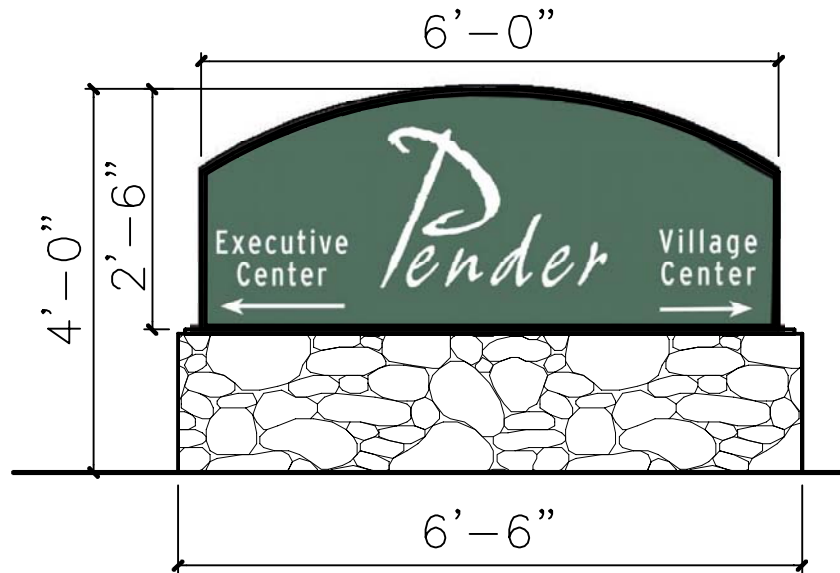

### **Pender Directional Signs (Primary):**

Directional Signs are located within the center to assist in general vehicular flow through the site. They direct customers and visitors to the shopping or office portions of the center. Signs will have internal illumination.

#### **DESCRIPTION:**

Letters routed in Hardiboard background mounted on stone base

Max height of sign 4'

Landscaping / Planting around sign

15 S.F. max sign area

#### **GRAPHICS / LETTERING**

Font: Grimshaw Hand, Myriad Pro



★ **Pender Directional Signs (Secondary):**

The secondary directional signs direct smaller traffic patterns such as parking areas or movement through the drive-through bank teller.

**DESCRIPTION:**

Metal Sign Faces and Sides

Max height of sign 2' - 6"

No Illumination

4 S.F. max sign area







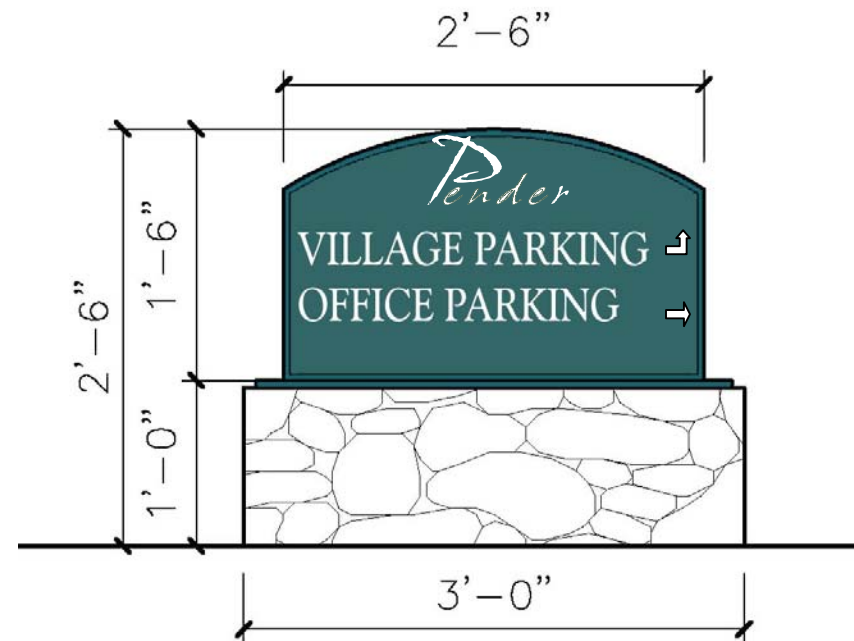
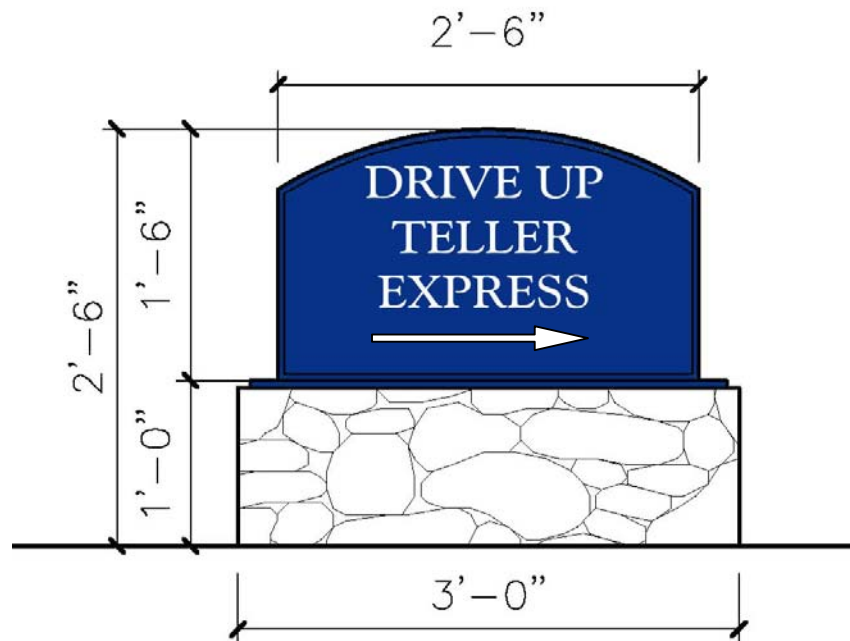

**GRAPHICS / LETTERING**

Font: Grimshaw Hand, Myriad Pro

All copy and arrows to be high performance white vinyl



# Tenant Signs

-  Anchor Tenant Signs Bldg A
-  Major Office Tenant B2
-  Major Tenant B1, B2
-  Tenant B1, B2
-  Office Tenant B2
-  Existing Office Building Signs
-  Office Building Signs
-  Pad Building Signs
-  Retail Blade Signs

Tenant Signs

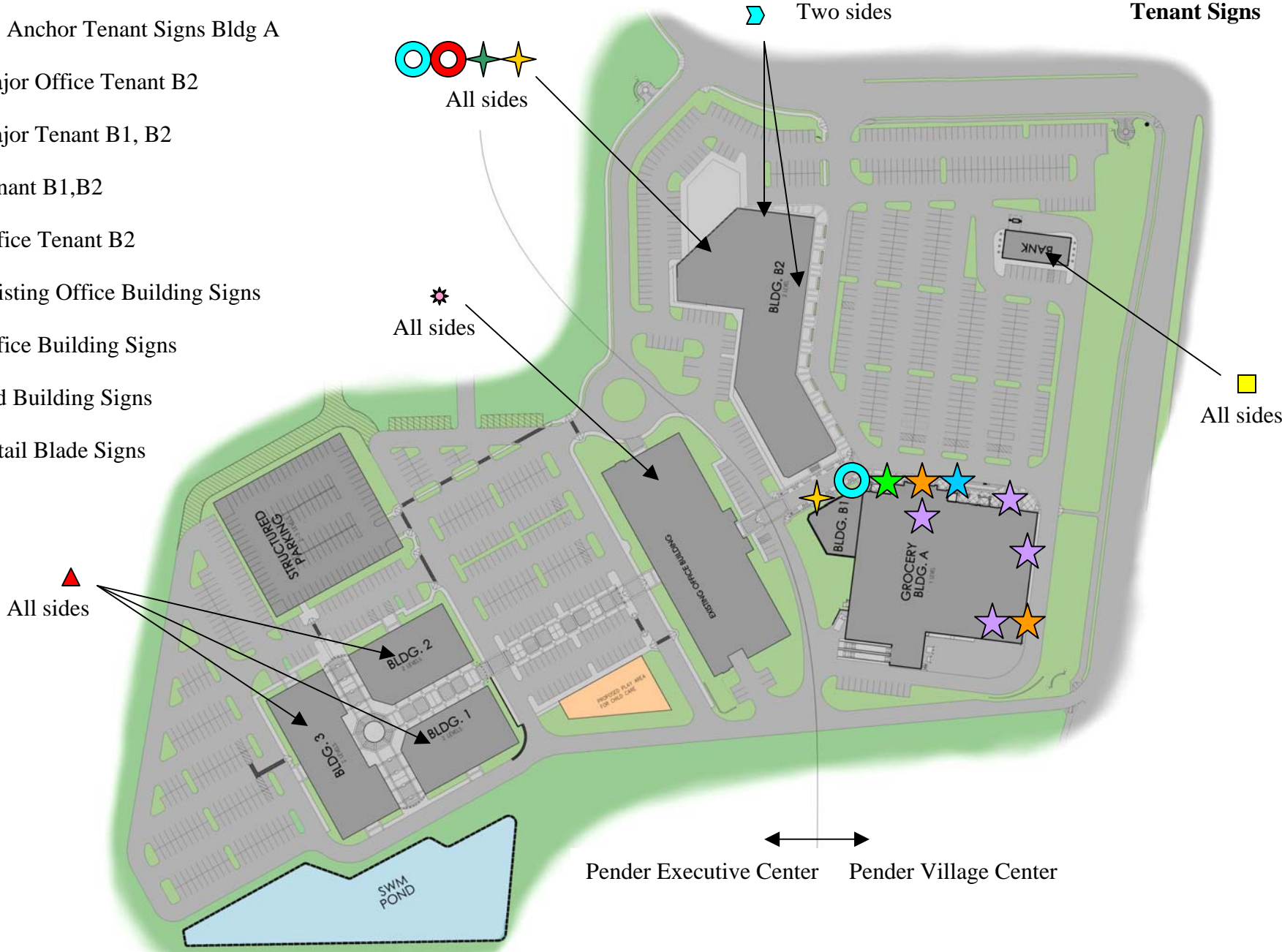

Comparison of Tenant Sign Sizes:



Diagram of an Anchor Tenant Sign. The word "ANCHOR" is written in a large, bold, serif font. A vertical dimension line to the left of the text indicates a maximum height of 3'-6".

Anchor Tenant Sign (Building A)

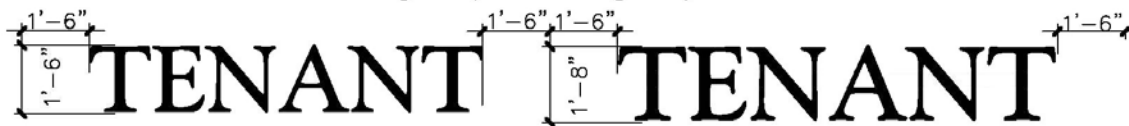

Diagram of two smaller tenant signs. The word "TENANT" is written in a bold, serif font. The first sign has a height dimension of 1'-6" and a width dimension of 1'-6". The second sign has a height dimension of 1'-8" and a width dimension of 1'-6".

Retail Signs(B1 & B2)  
Office Signs (B2)  
Pad Building  
Office Building (1,2,3)

3901 Fair Ridge Drive  
Office Building



Diagram of a Major Tenant Sign. The word "Major Tenant" is written in a large, bold, serif font. A vertical dimension line to the left of the text indicates a height of 3'-6". A horizontal dimension line above the text indicates a width of 1'-6".

Major Retail (Building B1 & B2) and Office (Building B2) Tenant Signs



Diagram of another Major Tenant Sign. The word "Major Tenant" is written in a large, bold, serif font. A vertical dimension line to the left of the text indicates a height of 3'-0". A horizontal dimension line above the text indicates a width of 1'-6".

Major Tenant Office Building (Buildings 1,2,3)

More than one line of text may be used so long as the total height of the lines together does not exceed the maximum height allowed.

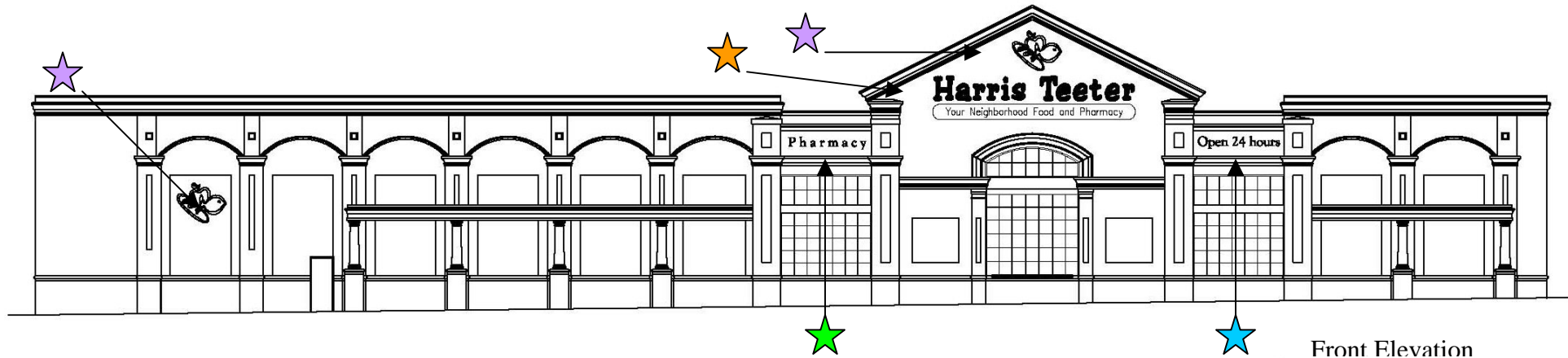

Front Elevation

★ Channel Letter Sign

★ Lighted Box Logo Signs

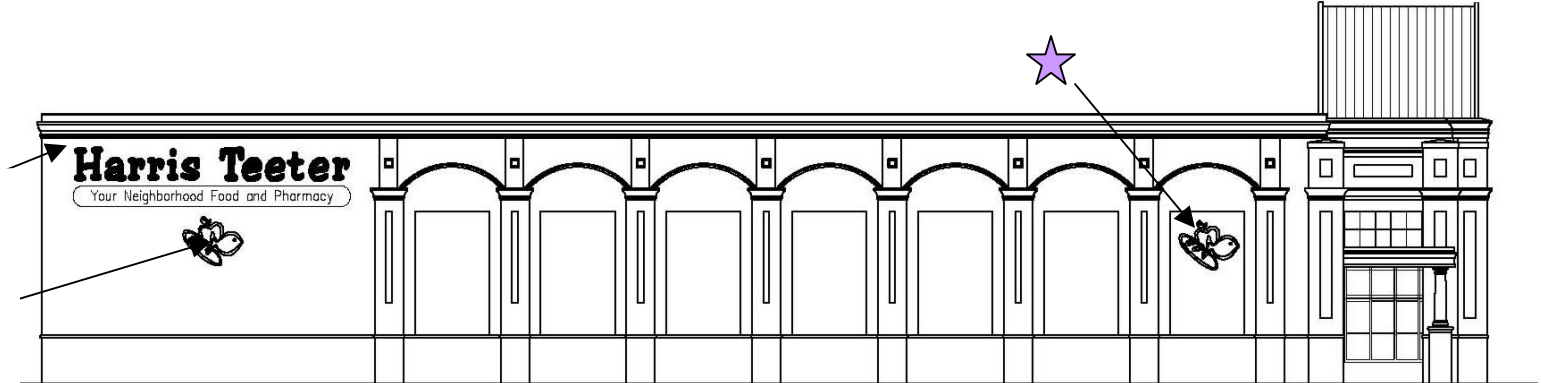

### Anchor Tenant Signs (Building A)

Tenants signs depicted reflect current leasing conditions. However, tenant may change and therefore signs are subject to modification as marketing trends prevail. Tenant will have the availability to display illuminated signs behind storefront glass.



★ **Anchor Tenant Signs (Building A) Type 1:**

DESCRIPTION:

Channel Letters on Raceway

Lighted box Tagline signs

1.5 sq. ft. per linear ft of frontage

The total amount of signage can be allotted where it best directs, advertises and informs.

GRAPHICS / LETTERING

Tenant Logos allowed

Size 42" x 30' 85 sq. ft.

Tagline Size 2'-6" x 27'-9" 69.5 sq. ft.



**Anchor Tenant Signs (Building A) Type 2:**

DESCRIPTION:

Channel Letters on Raceway

GRAPHICS / LETTERING

Size 1'6" x 12'-0" 18 sq. ft.

## ★ **Open 24 Hours**

### **Anchor Tenant Signs (Building A) Type 3:**

**DESCRIPTION:**

Channel Letters on Raceway

**GRAPHICS / LETTERING**

Size 1'-6" x 16'-0" 24 sq. ft.



### ★ **Anchor Tenant Signs (Building A) Type 4:**

**DESCRIPTION:**

Open face channel letter on raceway

**GRAPHICS / LETTERING**

Tenant logo

Size 5'-0" x 7'-0" 35 sq. ft.

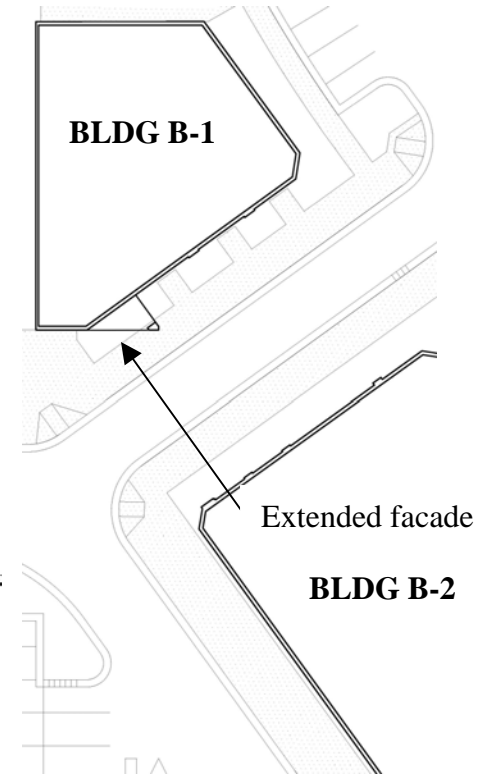

### Building B1 Retail Tenant Signs:

The positioning of building B-1 in relationship to B-2 limits visibility of the side tenant's signage so there is a signage feature to display the signs for those tenants whose signage is less visible. This allows customers to approach from the primary parking field and directs them to the stores they are interested in visiting.

#### DESCRIPTION:

Channel Letters with interior illumination on raceway  
 18" from Tenant demising walls  
 Signs may be dispersed in varying configurations  
 The total amount of signage can be allotted where it best directs, advertises and informs. Therefore signage for tenants whose visibility is limited will be given signage on more visible signage feature.

- ★ **RETAIL TENANT**  
 Tenant Logos allowed max height 3'-0"  
 Letter Height: 2'-0"  
 60 SF maximum sign area
- ⊙ **MAJOR RETAIL TENANT-** (a major retail tenant is defined as a tenant that occupies 3500 or more SF on the first floor of either buildings B1 or B2)  
 Letter Height: 3' 6"  
 Logo height: 4'-0"  
 75 SF maximum sign area





## 1<sup>st</sup> Floor Retail Tenant Signs (Building B2):

### DESCRIPTION:

Channel Letters with interior illumination on raceway  
 18" from Tenant demising walls  
 Signs may be dispersed in varying configurations  
 The total amount of signage can be allotted where it best directs, advertises and informs.



**RETAIL TENANT**  
 Tenant Logos allowed max height 3'-0"  
 Letter Height: 2'-0"  
 60 SF maximum sign area



**MAJOR RETAIL TENANT** - (a major retail tenant is defined as a tenant that occupies 3500 or more SF on the first floor of either buildings B1 or B2)  
 Letter Height: 3' 6"  
 Logo height: 4'-0"  
 75 SF maximum sign area



## 2<sup>nd</sup> Floor Office Tenant Signs (Building B2):

### DESCRIPTION:

Channel Letters with interior illumination on raceway  
 18" from Tenant demising walls  
 Signs may be dispersed in varying configurations  
 The total amount of signage can be allotted where it best directs, advertises and informs.



### OFFICE TENANT

Tenant Logos allowed max height 3'-0"  
 Letter Height: 18"  
 60 SF maximum sign area



MAJOR OFFICE TENANT - (a major office tenant is defined as a tenant that occupies 3500 or more SF on the second floor of building B2)

Letter Height: 3' 6"  
 Logo height: 4'-0"  
 75 SF maximum sign area

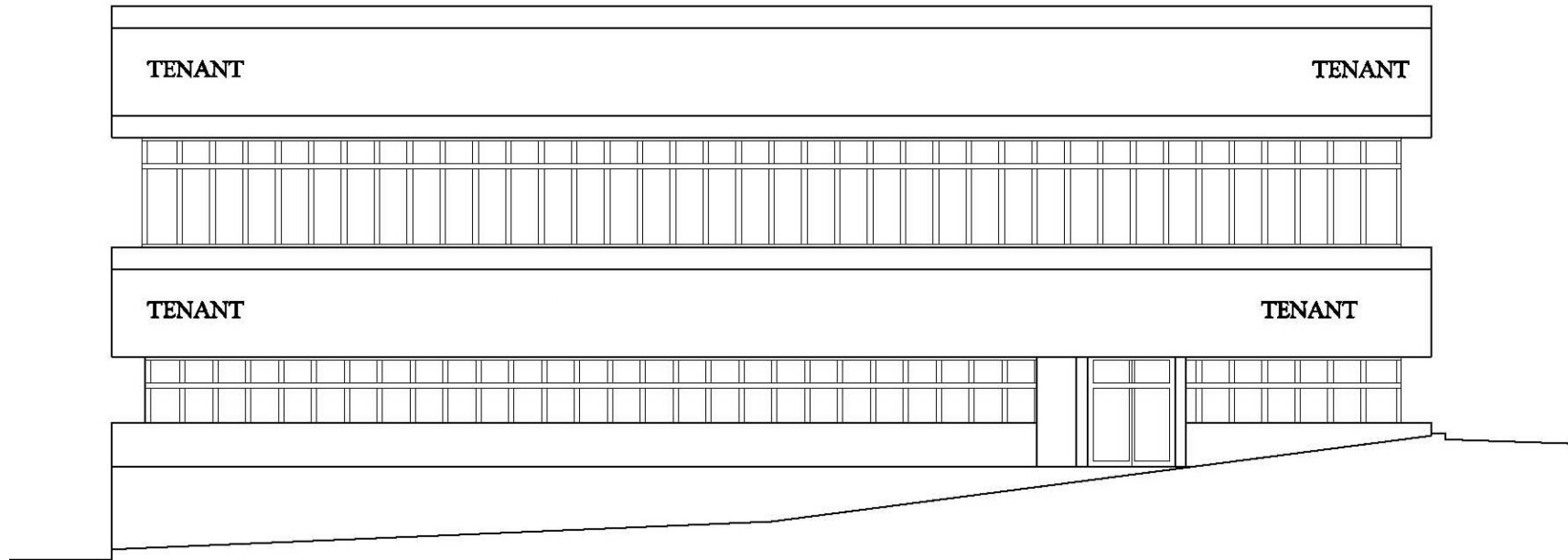

**\* 3901 Fair Ridge Drive (Existing Office Building):**

**DESCRIPTION:**

Interior Illuminated Channel Letters on Raceways  
Signs may be dispersed in varying configurations  
1.5 S.F. per linear ft of frontage

**GRAPHICS / LETTERING**

Font: Goudy  
Color: Multiple Colors  
Letter Height: 1'-8"  
Logo height: 2'-6"  
4 tenant signs per building  
90 SF maximum



▲ **Office Building (Buildings 1, 2, and 3):**

**DESCRIPTION:**

Pin Mounted (non illuminated) signs  
Signs may be dispersed in varying configurations  
Font: Goudy  
Color: Black

**TENANT:**  
30 SF maximum sign area  
Letter Height: 18"  
Tenant Logos allowed 30" height Max

**MAJOR TENANT** (A major office tenant is defined as a tenant occupying 5,000 or more SF of buildings 1, 2, or 3.)  
Letter Height: 3'-6"  
Logo Height: 3'-6"  
60 SF maximum sign area

### ■ Pad Building (Bank):

Tenant signs depicted reflect current leasing conditions. However tenant may change and therefore signs are subject to modification as marketing trends prevail.

#### DESCRIPTION:

Channel Letters with interior illumination

Signs may be dispersed in varying configurations (for example 37.5 sq ft on each of 4 sides, or 75 sq ft on each of 2 sides)

150 S.F. of building mounted signage (not to exceed 1.5 S.F. per linear ft of frontage on street faces), and additional incidental directional signs and ATM signage not to exceed 50 S.F. will be allowed for the pad building.

The total amount of signage can be allotted where it best directs, advertises and informs.

#### GRAPHICS / LETTERING

Font and color: Tenant logos and color schemes allowed

Letter Height: Up to 24" high if signs are limited to two sides of the building

Up to 18" high if signs are on more than two sides of the building



PROPOSED INDIVIDUALLY MOUNTED 18" CHANNEL LETTERS AS SHOWN  
LETTERS - #2157 RED PLEX. FACES / BLACK SIDE RETURNS / 434U TRIMCAP

**FRONT ELEVATION**

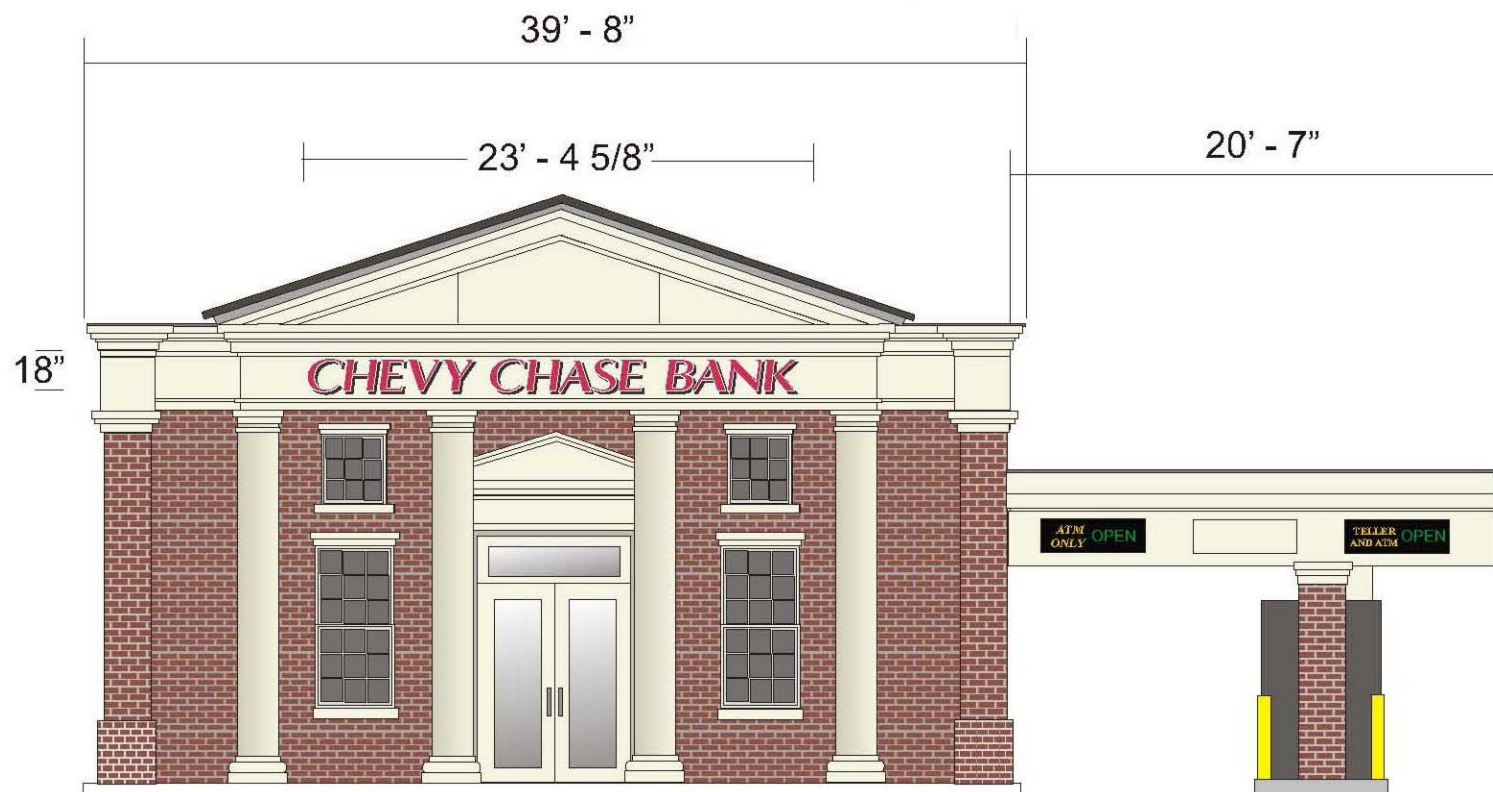

PROPOSED INDIVIDUALLY MOUNTED 18" CHANNEL LETTERS AS SHOWN  
LETTERS - #2157 RED PLEX. FACES / BLACK SIDE RETURNS / 434U TRIMCAP

**REAR ELEVATION**



PROPOSED INDIVIDUALLY MOUNTED 18" CHANNEL LETTERS AS SHOWN  
LETTERS - #2157 RED PLEX. FACES / BLACK SIDE RETURNS / 434U TRIMCAP

**DRIVE-THRU ELEVATION**



# Pender Sign Guidelines

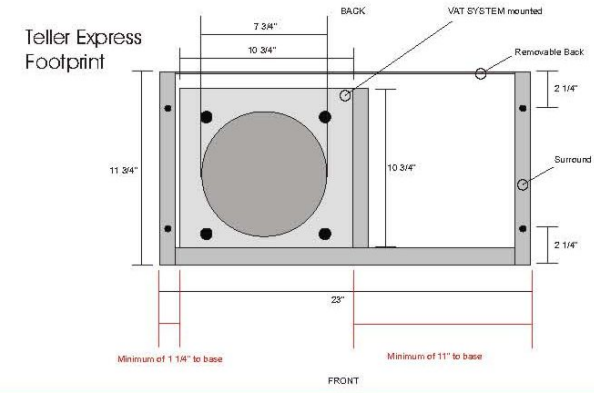
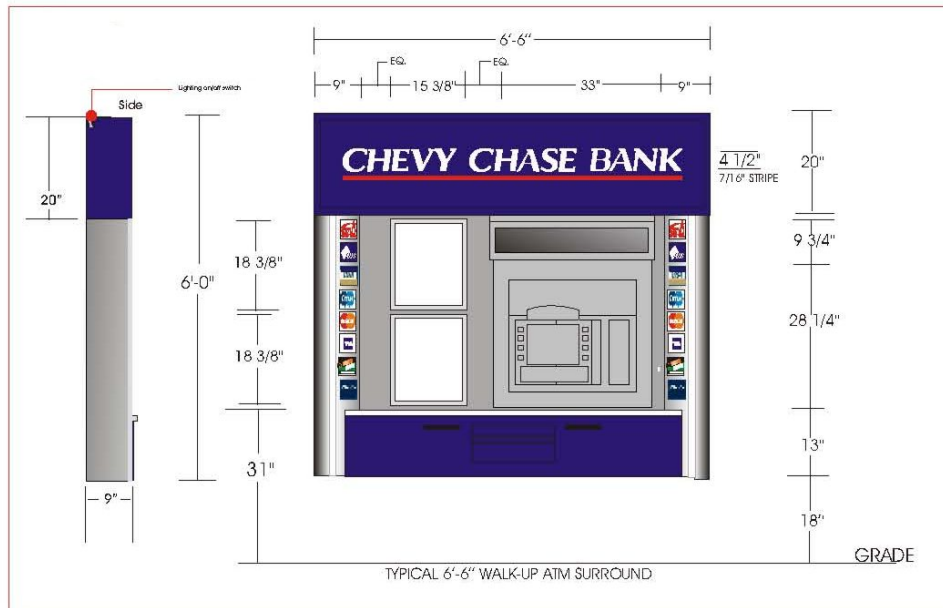

► **Retail Blade Signs (Canopy Mounted):**

Blade signs are used to provide tenant names for pedestrians walking parallel to the building face, who would not have an easily visible view of the tenant signage. These signs are suspended from the canopy above and are located to provide optimal information as the tenant entrances.

**DESCRIPTION:**

**Under Canopy Tenant Sign**

- Maximum of 1 sign per tenant (to be installed by Landlord)
- Graphics on 2 sides
- 5 S.F. max
- Single color

Wooden or Metal Blade sign with Painted Tenant Name and Shopping Center Logo (Logo Optional)

Tenant logos not allowed

**GRAPHICS / LETTERING:**

Lettering: Painted lettering

Letter Height: 4"

Letter Color: Green PMS 5545

Sign Color: Gold 7406

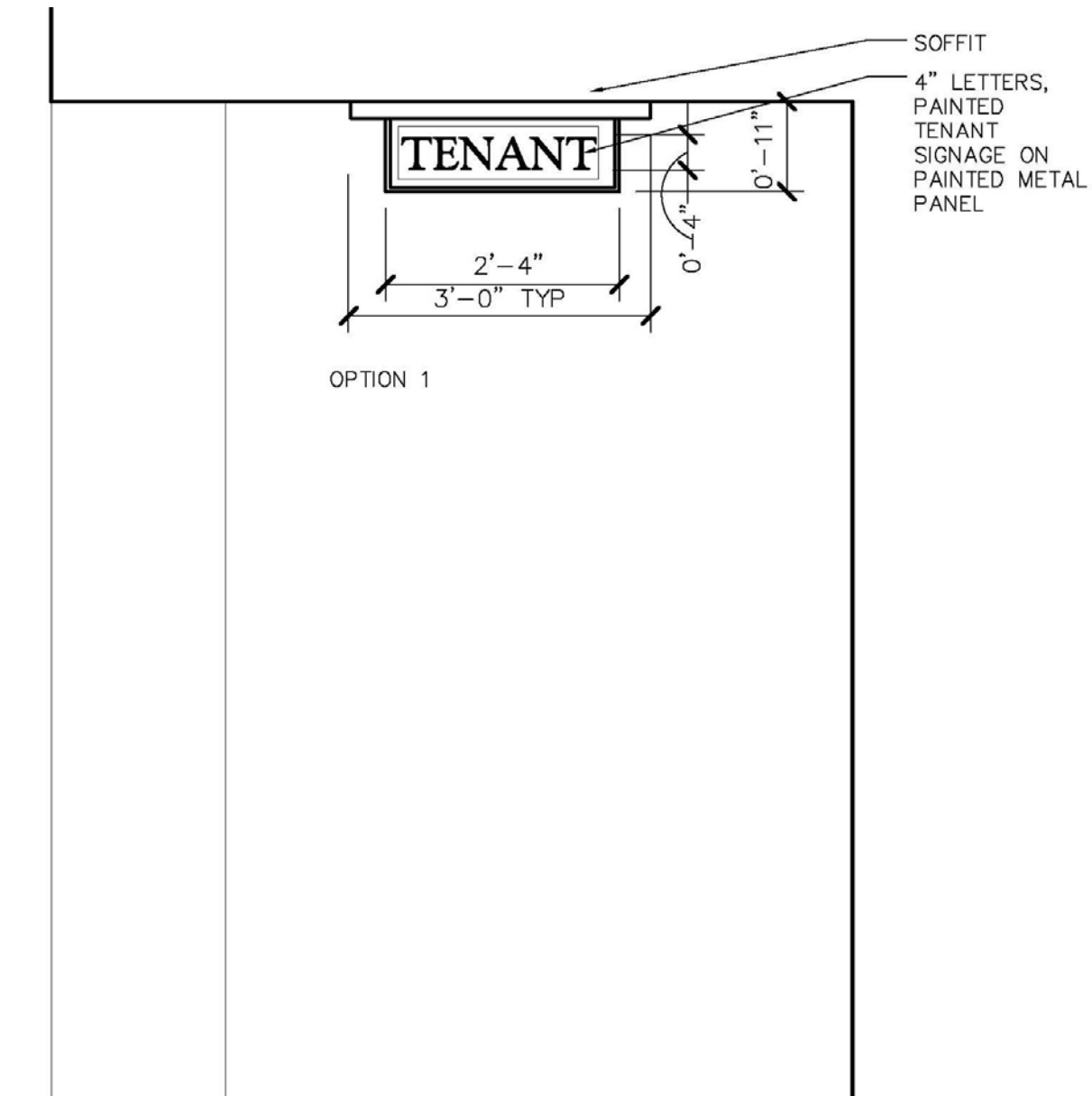

► **Retail Blade Signs (Cantilever Mounted):**

These signs are suspended from the awning above and are located to provide optimal information as the tenant entrances.

**DESCRIPTION:**

Blade Sign mounted on cantilevering Metal frame.

- Maximum of 1 sign per tenant (to be installed by Landlord)
- Graphics on 2 sides
- 5 S.F. max
- Single color

Wooden or Metal Blade sign with Painted Tenant Name and Shopping Center Logo (Logo Optional)

Tenant logos not allowed

**GRAPHICS / LETTERING**

Lettering: Painted lettering

Letter Height: 4"

Letter Color: Green PMS 5545



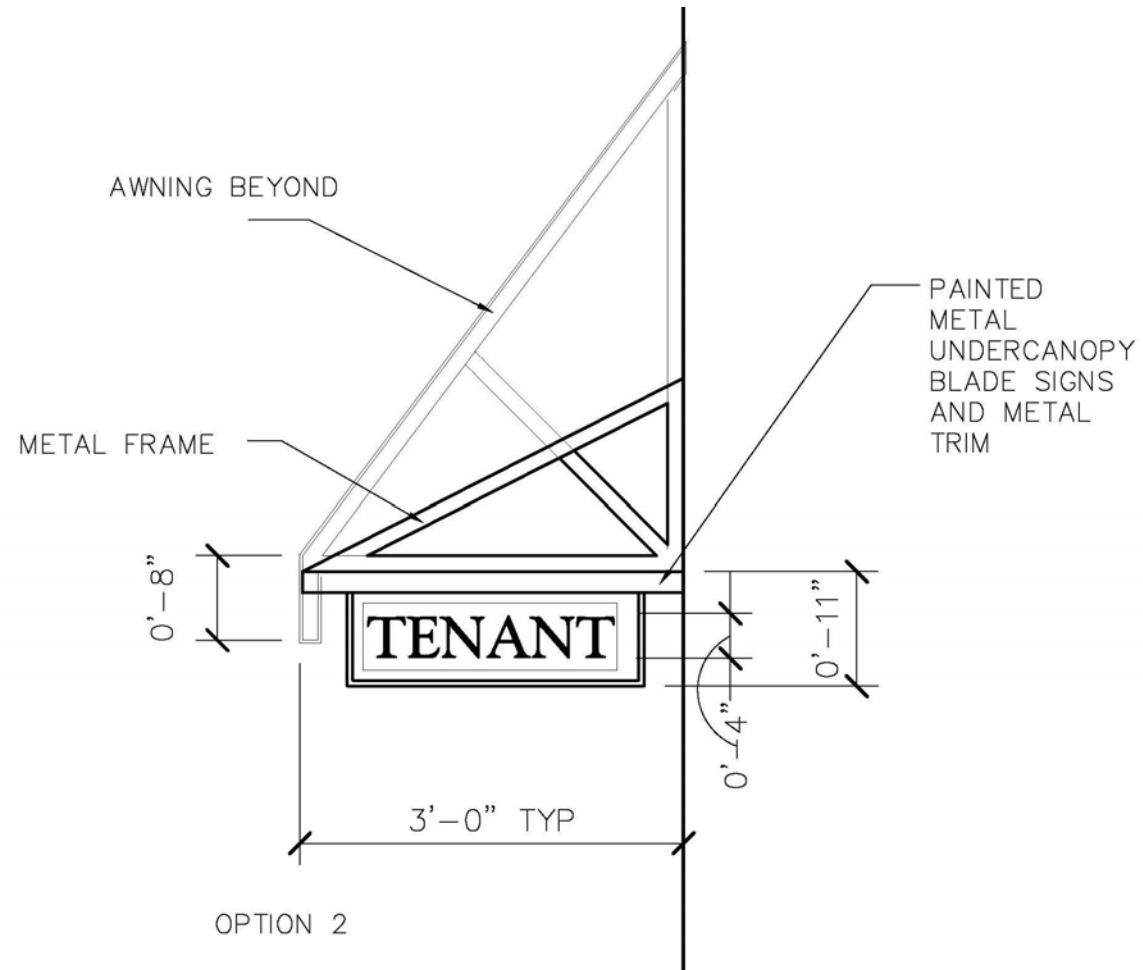



Sign Color: Gold 7406



## Miscellaneous Signs

Miscellaneous signs are needed throughout the site to provide additional information. Some of these signs mark site amenities such as the parking garage. Others inform about conditions such as the storm water management pond, or provide community spirit through season, and community banners. Because of the fluctuations in design and market conditions, flexibility is needed to relocate signs for future leasing conditions; sign locations may be modified by the Fairfax County Department of Planning and Zoning as long as they are in substantial conformance with the applicable CSP.

Miscellaneous Signs

-  Parking Garage (Vehicular)
-  Parking Garage (Pedestrian)
-  Protected Natural Area
-  Light Pole Banners
-  Historical Marker
-  Flags

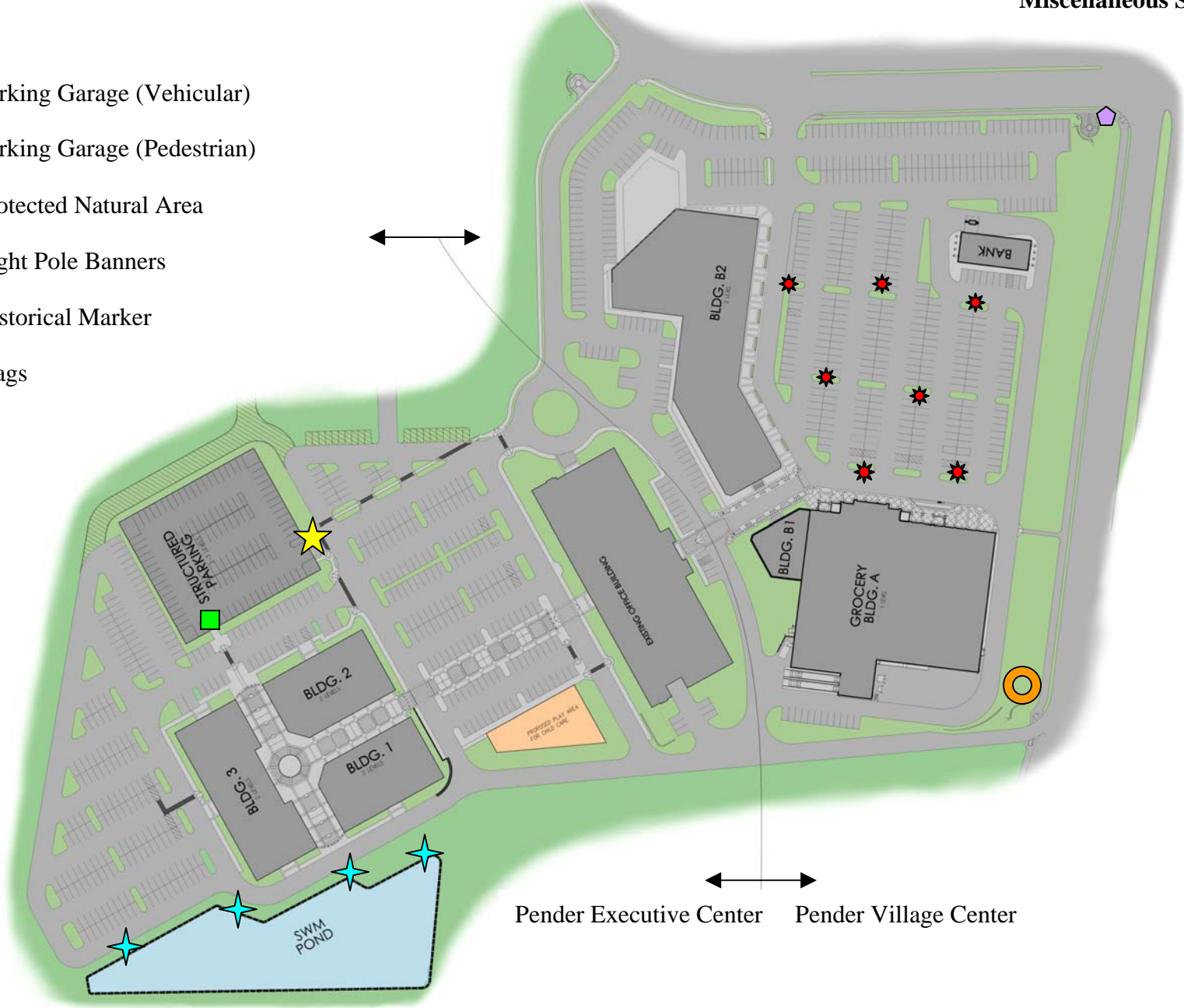

Pender Executive Center    Pender Village Center

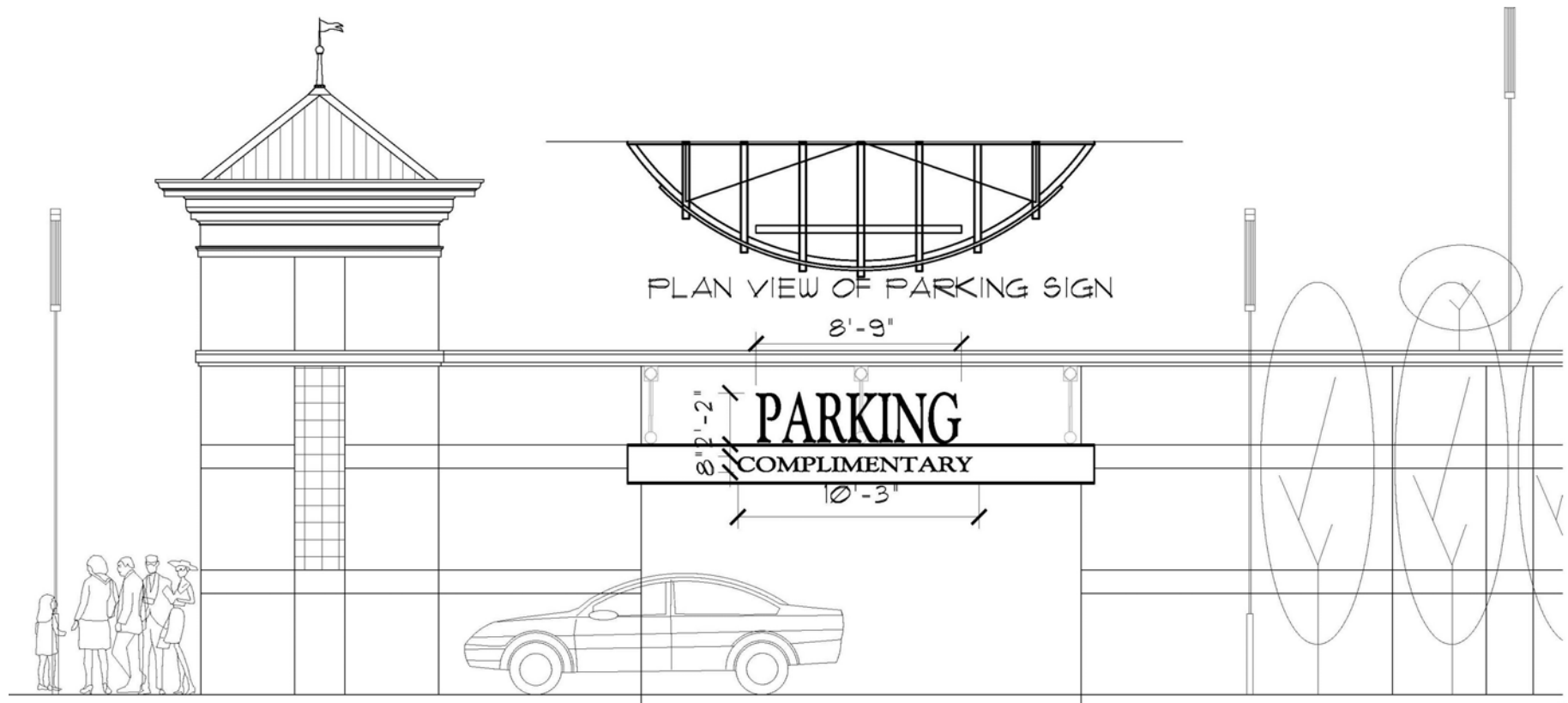

★ **Parking Garage Signs (Vehicular):**

The parking garage serves the office portion of the center. Sign used to provide identification of the parking garage for vehicular traffic. One Parking identification sign will be permitted for each garage entrance. Accessory signs, which inform the visitor of fees, regulations, clearances, and other information, will be permitted not to exceed 15 square feet in area on the outside of the garage. The accessory signs may be either building mounted or free standing, and will complement the architectural style of the garage.

**DESCRIPTION:**  
 Letters Mounted on Metal Canopy  
 Maximum Sign area 30 S.F.

**GRAPHICS / LETTERING**  
 Font: Goudy  
 Letter Height: 2'2"

■ **Parking Garage Signs (Pedestrian):**

Sign used to provide identification of the parking garage for vehicular traffic.

DESCRIPTION:

- Graphics on 1 side
- 5 S.F. max
- Single color

Wooden or metal blade sign with painted parking sign and shopping center logo (logo optional)

GRAPHICS / LETTERING

Font: Goudy

Letter Height: 1 ft max

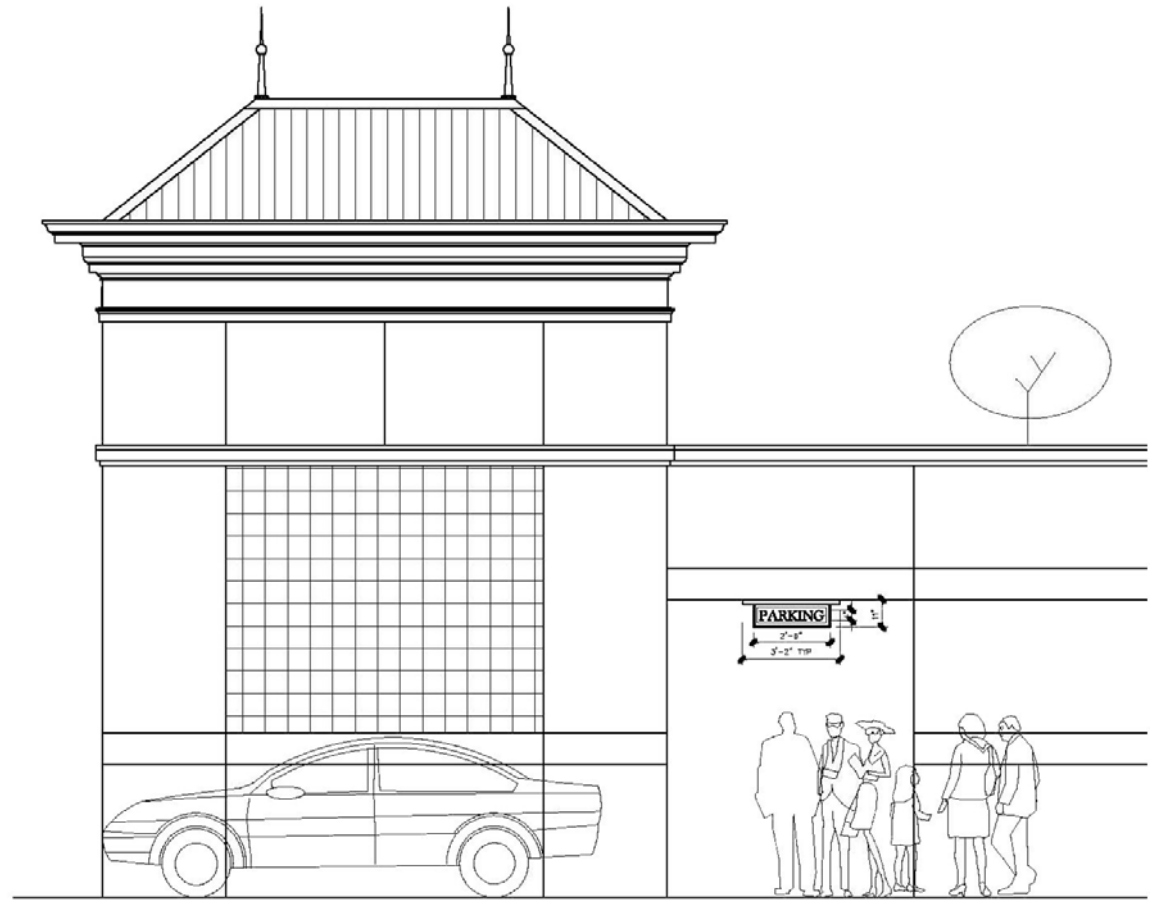

**★ Protected Natural Area Sign:**

Sign used to preserve the storm water management pond for natural plants and wildlife, and to protect visitors from potential harm.

**DESCRIPTION:**

Fence Mounted Protected Natural Area Sign

- Signs as needed to protect natural areas
- Maximum size of sign panel 3 s.f.
- Maximum height from ground 4'
- Graphics on 1 side

Mounted on Fence

Wooden or aluminum sign

**GRAPHICS / LETTERING**

Letter Height: 2.25"

No Illumination

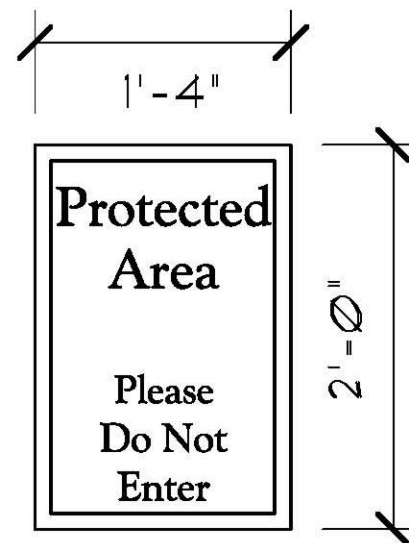



**\* Light Pole Banners:**

Light pole banners are used to create a festive and seasonal atmosphere. They may contain the name and logo of the center but will not contain specific Tenant names or logos. They may advertise community or center sponsored events.

**DESCRIPTION:**

Banners Mounted on Light poles in Parking Areas

18 S.F. per Banner

Banners may be constructed using metal or durable fabrics.

**GRAPHICS / LETTERING**

Seasonal Graphics Banners and

Shopping Center Identification Banners

7' x 2' 6" Banners

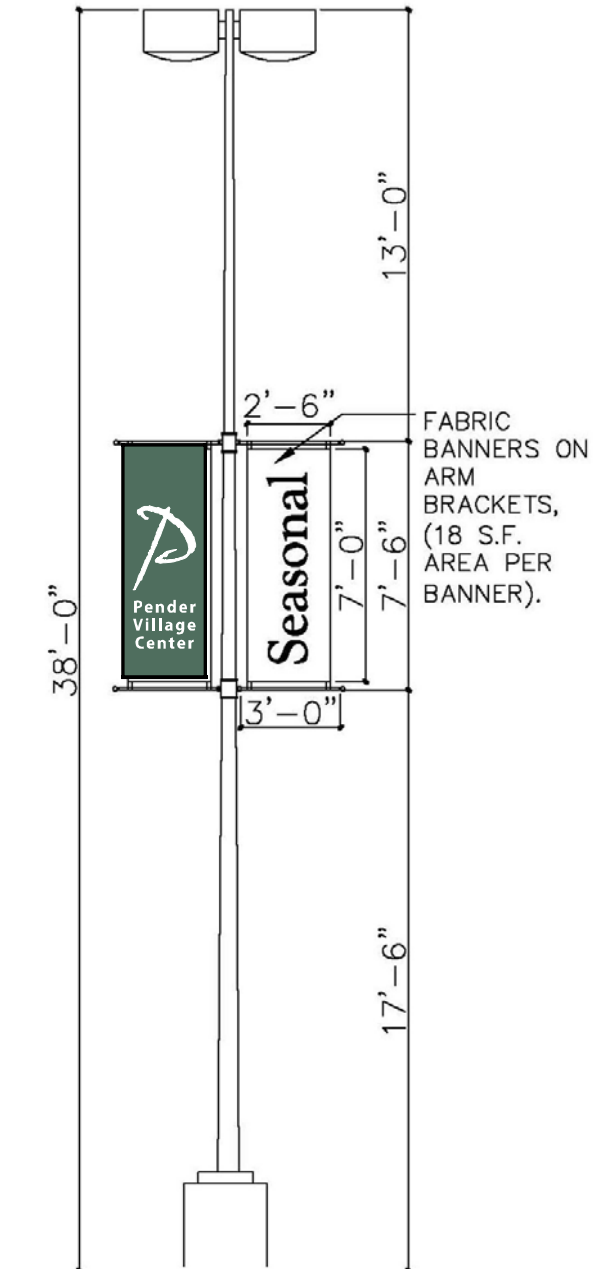

◆ **Historical Marker:**

The historical marker will contain a description of the battle of Chantilly and its historical significance. It will be the standard state historical marker.

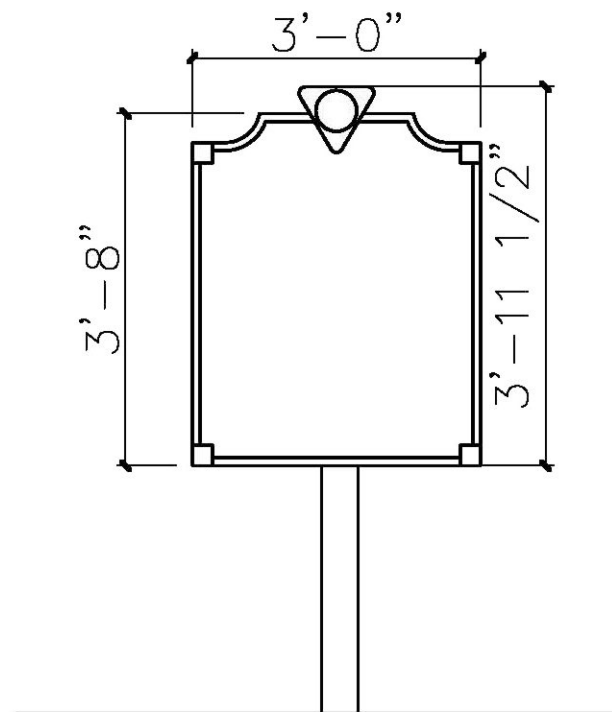

 **Flags:**

**DESCRIPTION:**

Flags mounted on Flagpoles, located at Pender Executive Center Monument Sign.

**GRAPHICS / LETTERING**

United States Flag

South Korean Flag

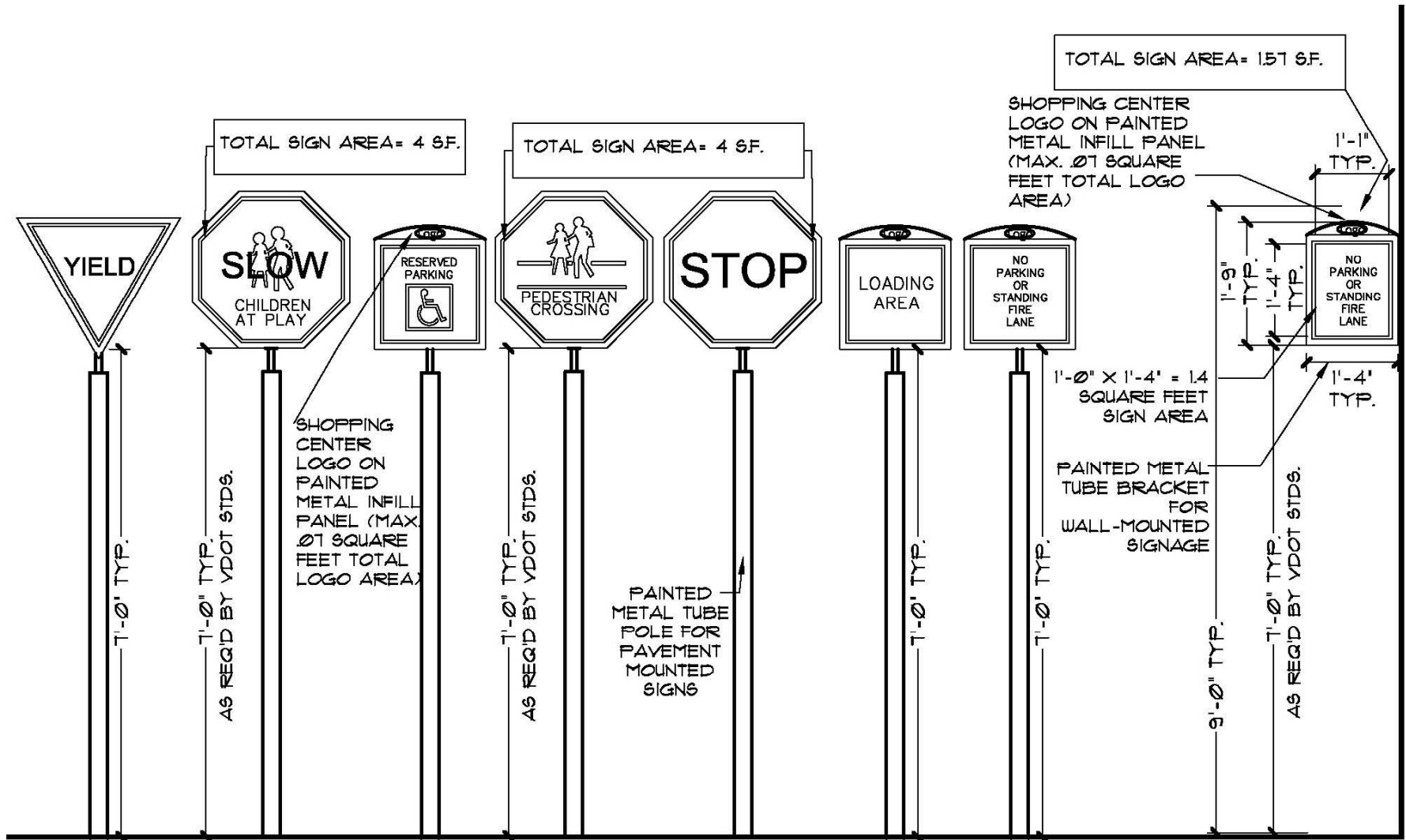

Informational Signs (Stop, Yield, Handicapped, No Parking, Play Area, Loading / Receiving, Pedestrian Crossing)

Traffic Signs used for regulatory purposes will be provided according to all local, state and federal regulations. Sign type, graphics, sizes and heights will conform to these regulations. Signs poles and backs will be painted consistent with the color scheme for the Center.